

REPARATION LEGEND	
①	HAIRLINE CRACK
②	SPALL CONCRETE PARCIAL
③	PATCHING TO BE REPAIR
④	HONEYCOMB.

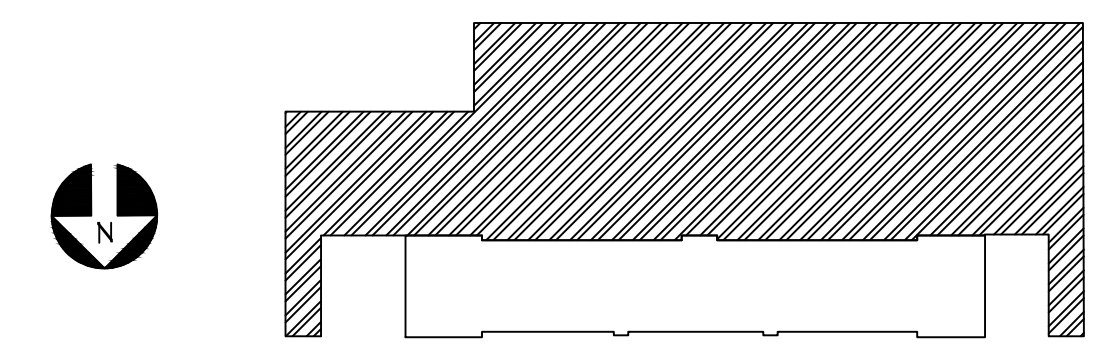

KEY PLAN

**GROUND FLOOR COLUMNS
PARKING WISTON TOWER**
SCALE: 3/32" = 1'-0"

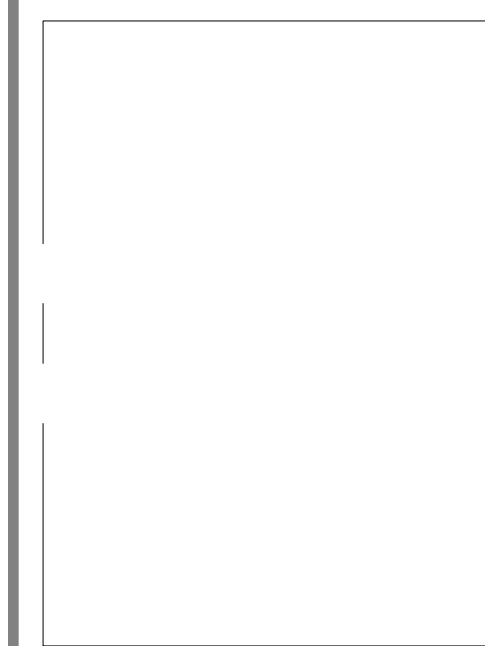

CONSULTING ENGINEER

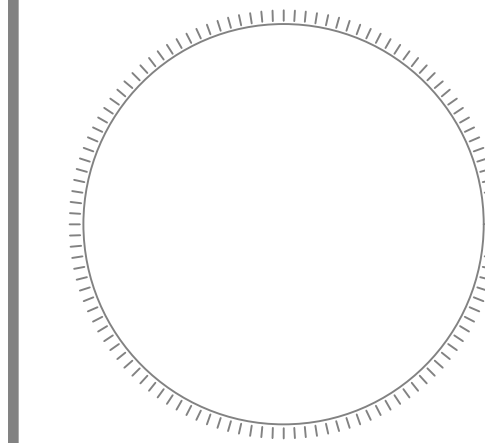

ALIOSKAR GANEM P.E.
FL. LIC. No. 74745

PROJECT NAME:
CONCRETE RESTORATION

PROJECT ADDRESS:
250 174th ST, SUNNY ISLES BEACH
33160 Florida.

REVISIONS DATE

REVISIONS	DATE

Project No:
Scale:
Date: AS NOTED
Drawn: 08-15-2021
Checked: A.G.
CAD File: A.G.

Drawing Title:

S-2

Sheet No: OF

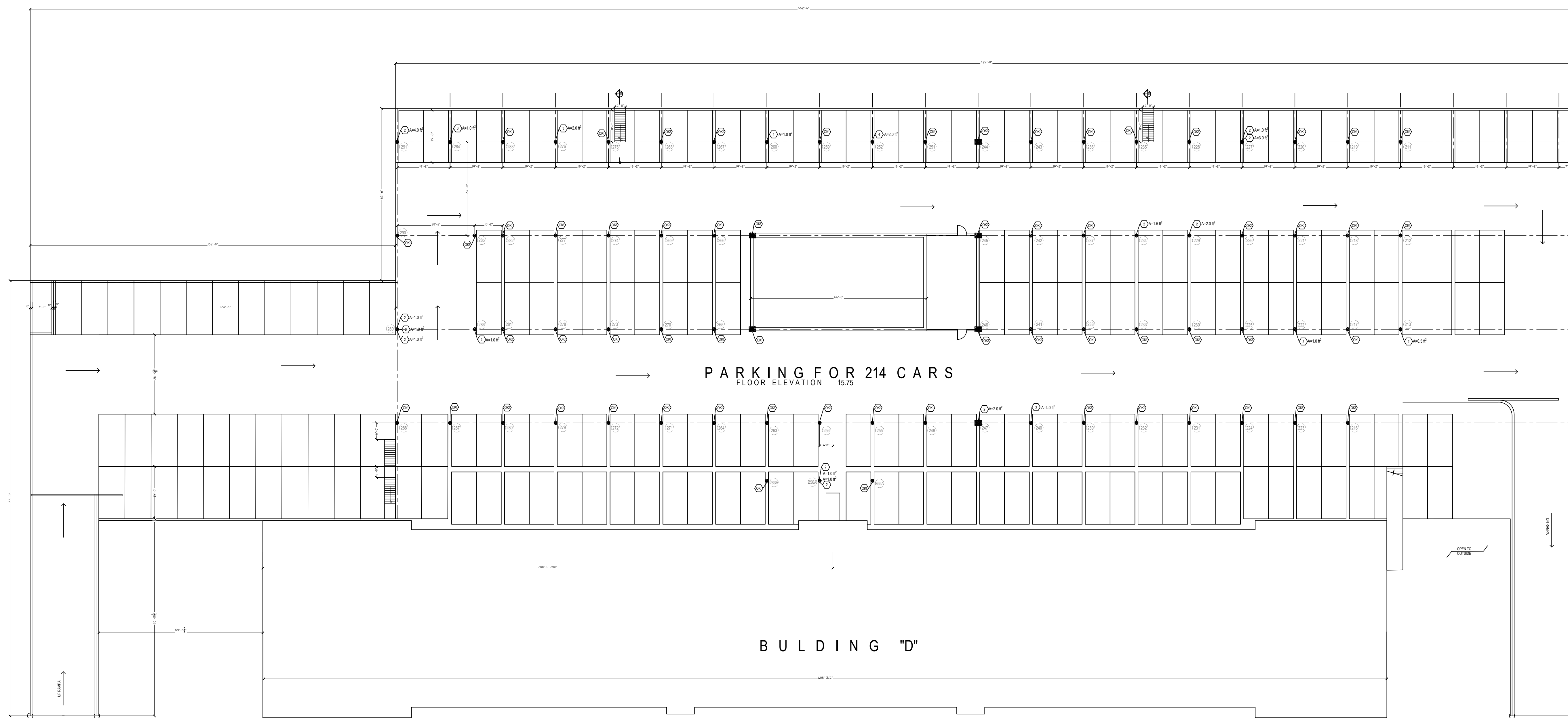

REPARATION LEGEND	
①	HAIRLINE CRACK
②	SPALL CONCRETE PARCIAL
③	PATCHING TO BE REPAIR
④	HONEYCOMB.

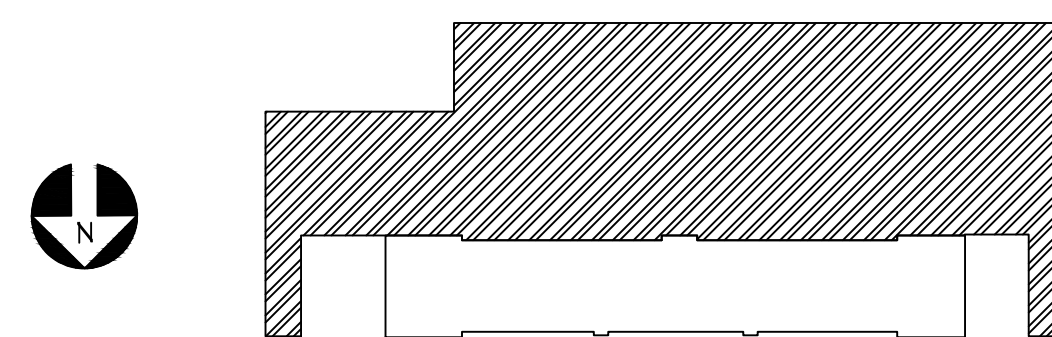

KEY PLAN

**SECOND FLOOR COLUMNS
PARKING WISTON TOWER**
SCALE: 3/32" = 1'-0"

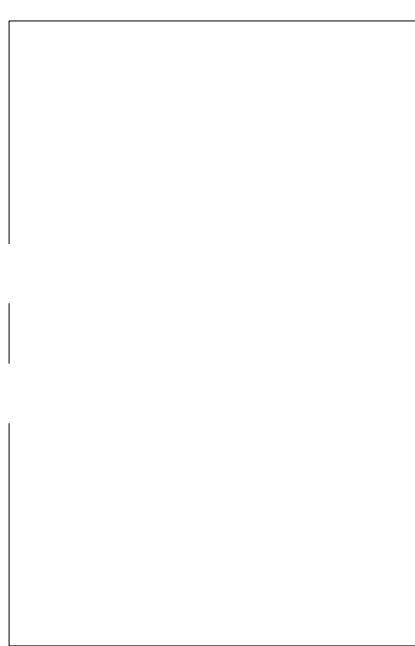

CONSULTING ENGINEER

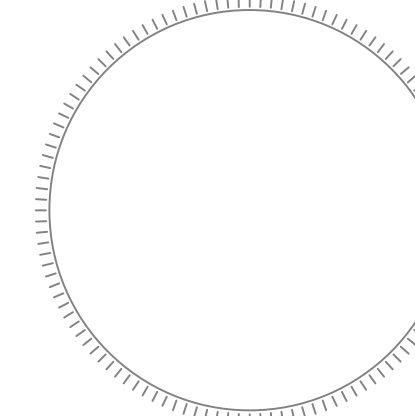

ALIOSKAR GANEM P.E.
FL. LIC. No. 74745

PROJECT NAME:
CONCRETE RESTORATION

PROJECT ADDRESS:
250 174th ST, SUNNY ISLES BEACH
33160 Florida.

REVISIONS DATE

REVISIONS	DATE

Project No:
Scale:
Date: AS NOTED
Drawn: 08-15-2021
Checked: A.G.
CAD File: A.G.

Drawing Title:

S-3

Sheet No: OF

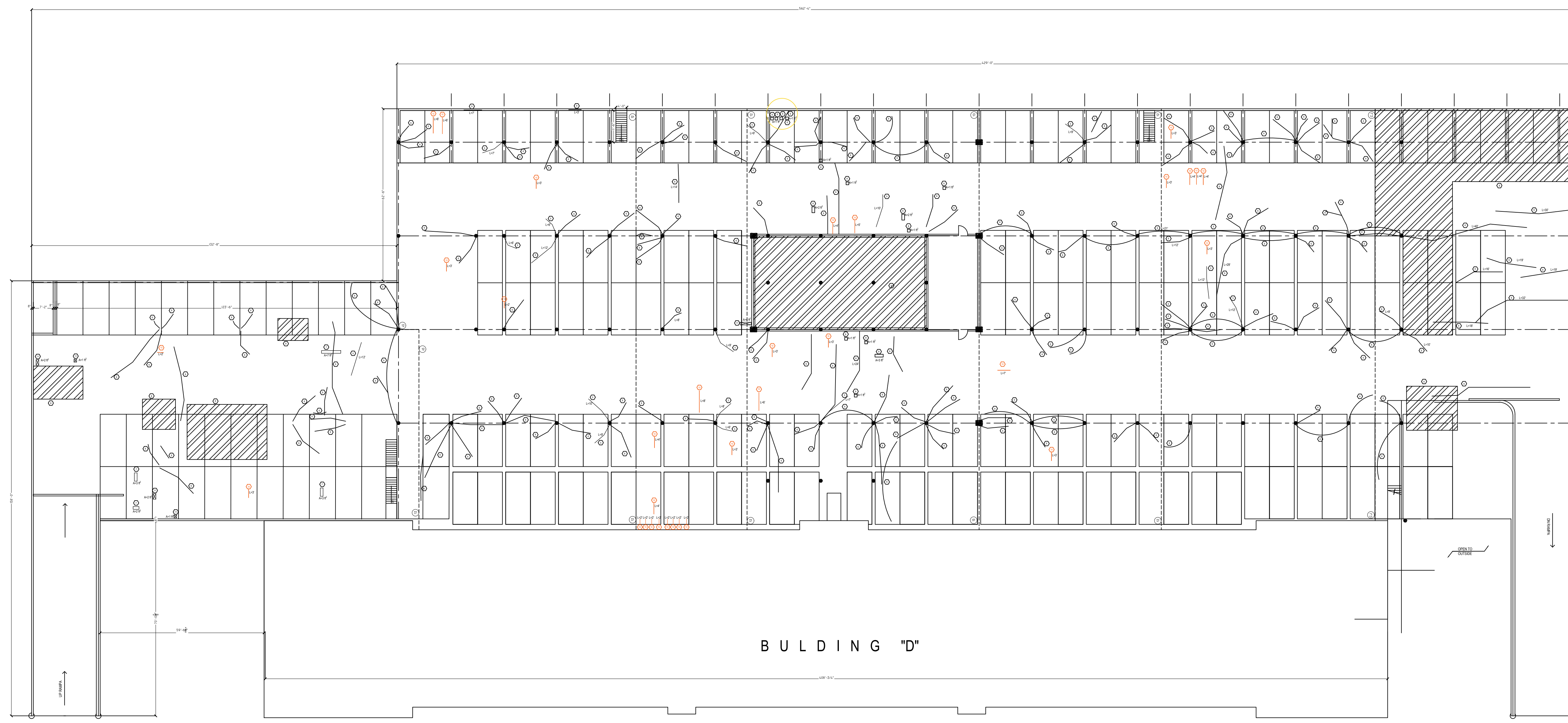

BUILDING "D"

REPARATION LEGEND

⑤	HAIRLINE CRACK SLAB OVERHEAD PARTIAL DEPTH
⑥	HAIRLINE CRACK SLAB FULL DEPTH
⑦	PARTIAL DEPTH SPALLED CONCRETE OVERHEAD
⑧	FULL DEPTH CONCRETE REPAIR SLAB
⑨	EDGE RAPAIR
⑩	JOIST REPAIR
⑪	BEAM REPAIR
⑫	COLD JOINT
⑬	EXPANSION JOINT
⑭	HAIRLINE CRACK ON SLAB PARTIAL DEPTH
⑮	PARTIAL DEPTH SPALLED CONCRETE

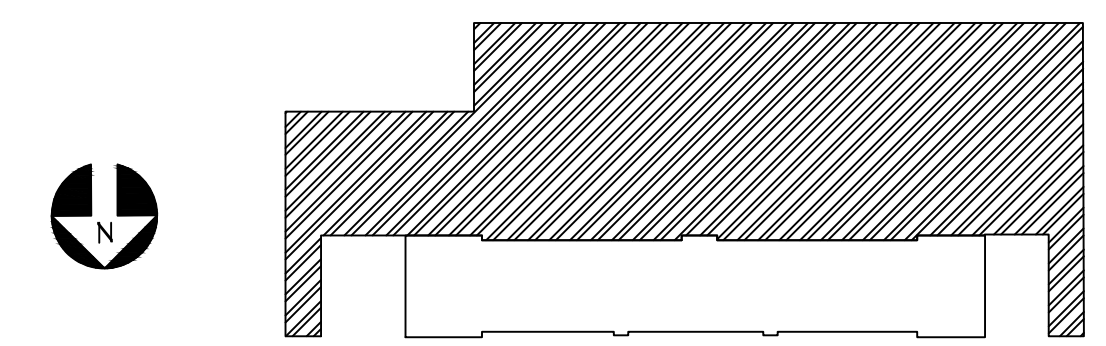

KEY PLAN

**GROUND FLOOR OVERHEAD
PARKING WISTON TOWER**

SCALE: 3/32" = 1'-0"

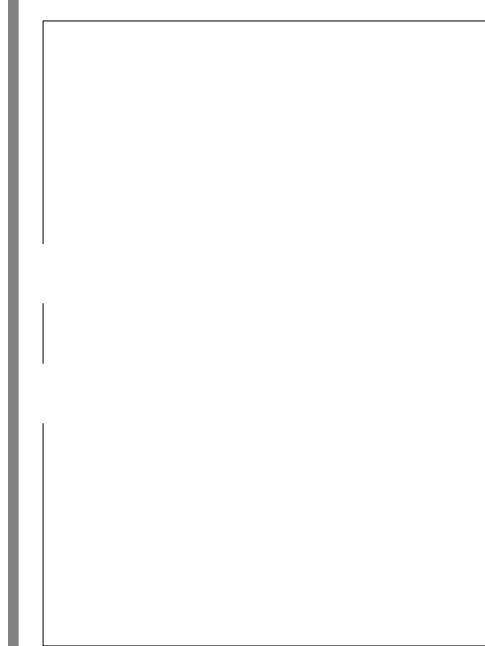

CONSULTING ENGINEER

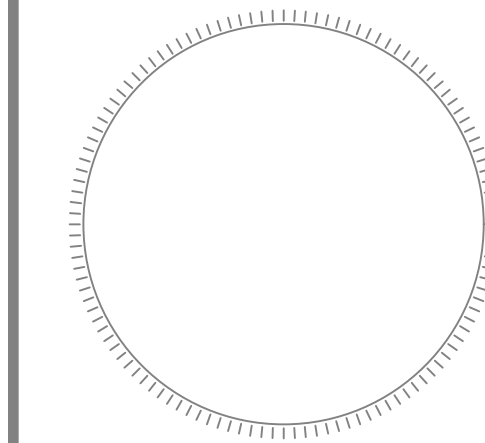

ALIOSKAR GANEM P.E.
FL. LIC. No. 74745

PROJECT NAME:
CONCRETE RESTORATION

PROJECT ADDRESS:
250 174th ST, SUNNY ISLES BEACH
33160 Florida.

REVISIONS	DATE

Project No:
Scale:
Date: AS NOTED
Drawn: 08-15-2021
Checked: A.G.
CAD File: A.G.

Drawing Title:

S-4

Sheet No: OF

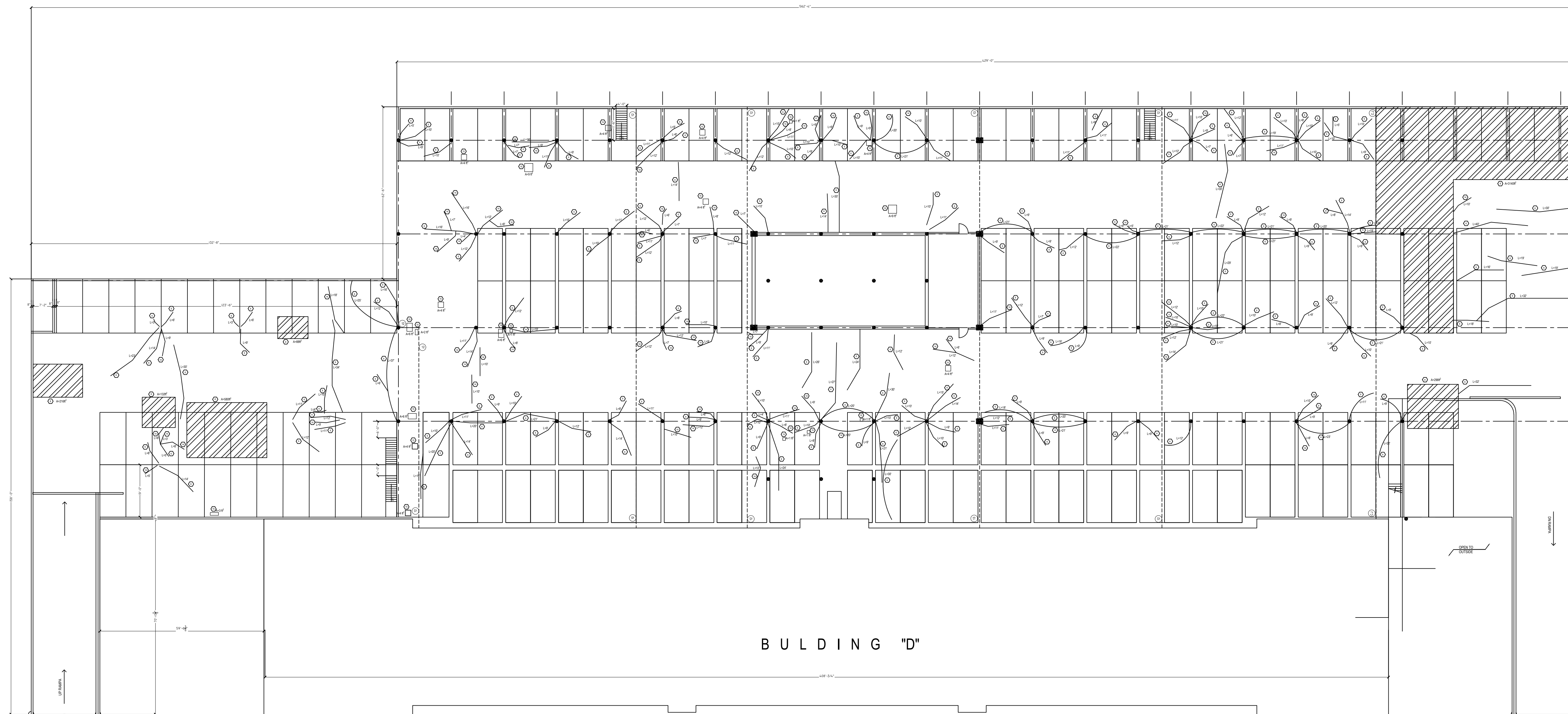

BUILDING "D"

REPARATION LEGEND

- ⑤ HAIRLINE CRACK SLAB OVERHEAD PARTIAL DEPTH
- ⑥ HAIRLINE CRACK SLAB FULL DEPTH
- ⑦ PARTIAL DEPTH SPALLED CONCRETE OVERHEAD
- ⑧ FULL DEPTH CONCRETE REPAIR SLAB
- ⑨ EDGE REPAIR
- ⑩ JOIST REPAIR
- ⑪ BEAM REPAIR
- ⑫ COLD JOINT
- ⑬ EXPANSION JOINT
- ⑭ HAIRLINE CRACK ON SLAB PARTIAL DEPTH
- ⑮ PARTIAL DEPTH SPALLED CONCRETE

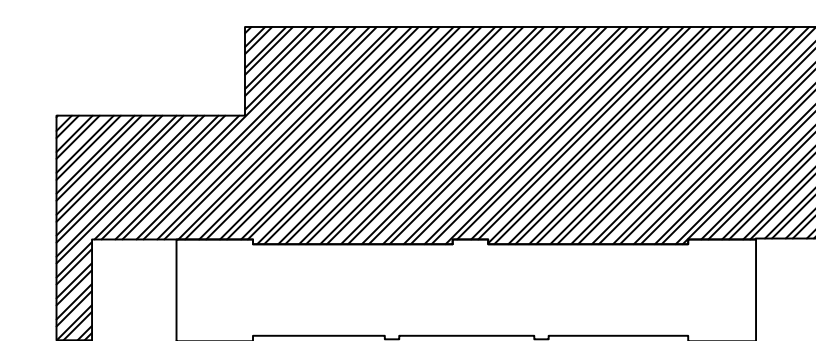

KEY PLAN

**SECOND FLOOR BOTTOM
PARKING WISTON TOWER**

SCALE: 3/32" = 1'-0"

PARKING GARAGE_WISTON_TOWER_CONCRETE RESTORATION.dwg

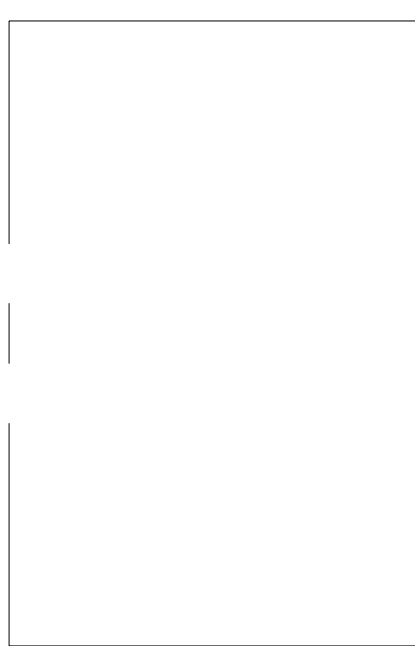

CONSULTING ENGINEER

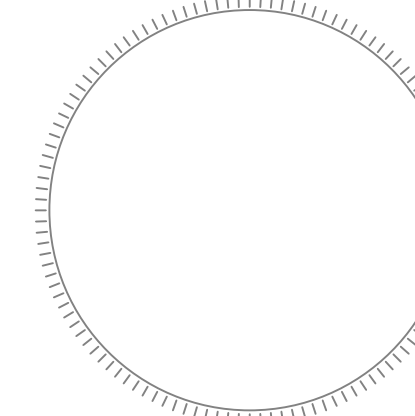

ALIOSKAR GANEM P.E.
FL. LIC. No. 74745

PROJECT NAME:
CONCRETE RESTORATION

PROJECT ADDRESS:
250 174th ST, SUNNY ISLES BEACH
33160 Florida.

REVISIONS DATE

REVISIONS	DATE

Project No:
Scale:
Date: AS NOTED
Drawn: 08-15-2021
Checked: A.G.
CAD File: A.G.

Drawing Title:

S-5

Sheet No: OF

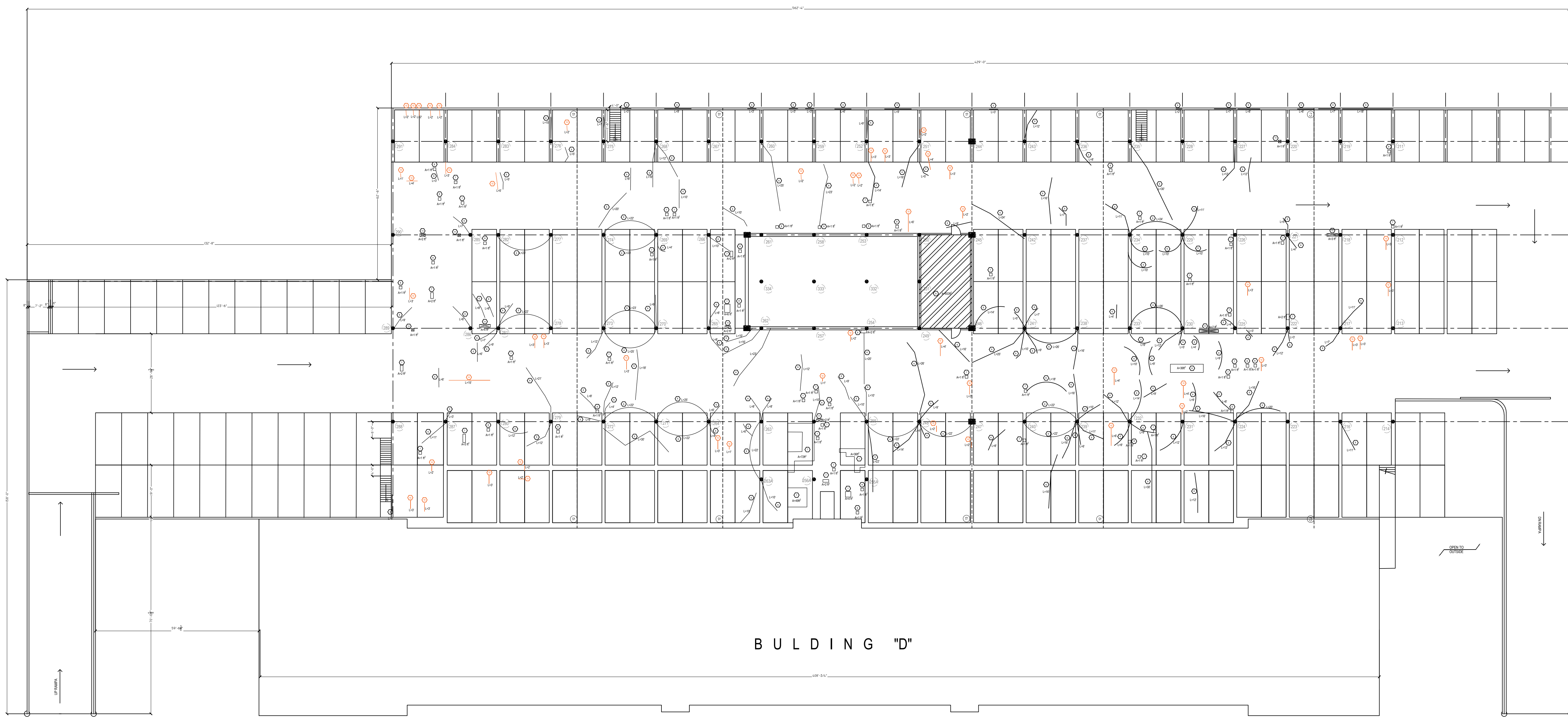

BUILDING "D"

REPARATION LEGEND	
⑤ /	HAIRLINE CRACK SLAB OVERHEAD PARTIAL DEPTH
⑥ /	HAIRLINE CRACK SLAB FULL DEPTH
⑦ □	PARTIAL DEPTH SPALLED CONCRETE OVERHEAD
⑧ □	FULL DEPTH CONCRETE REPAIR SLAB
⑨ /	EDGE RAPAIR
⑩ /	JOIST REPAIR
⑪ ⊗	BEAM REPAIR
⑫ - - -	COLD JOINT
⑬ - - -	EXPANSION JOINT
⑭ /	HAIRLINE CRACK ON SLAB PARTIAL DEPTH
⑮ □	PARTIAL DEPTH SPALLED CONCRETE

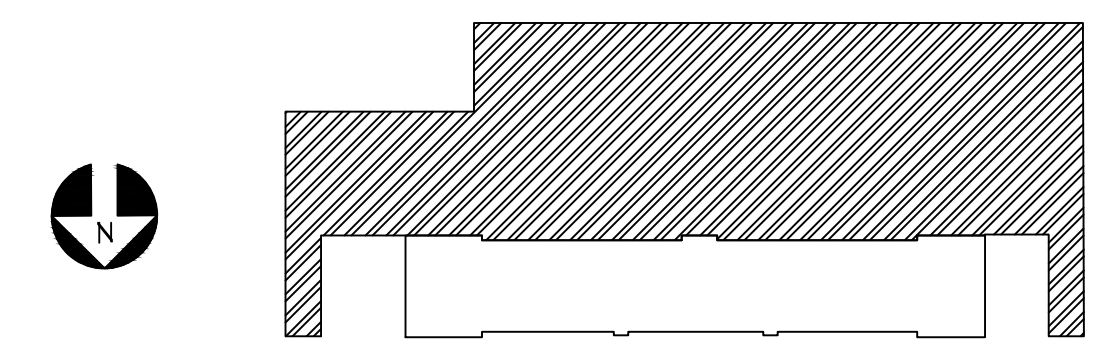

KEY PLAN

**SECOND FLOOR OVERHEAD
PARKING WISTON TOWER**

SCALE: 3/32" = 1'-0"

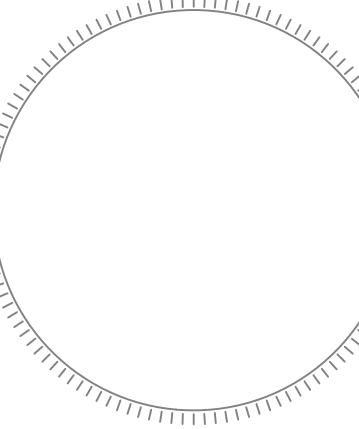

REVISIONS	DATE

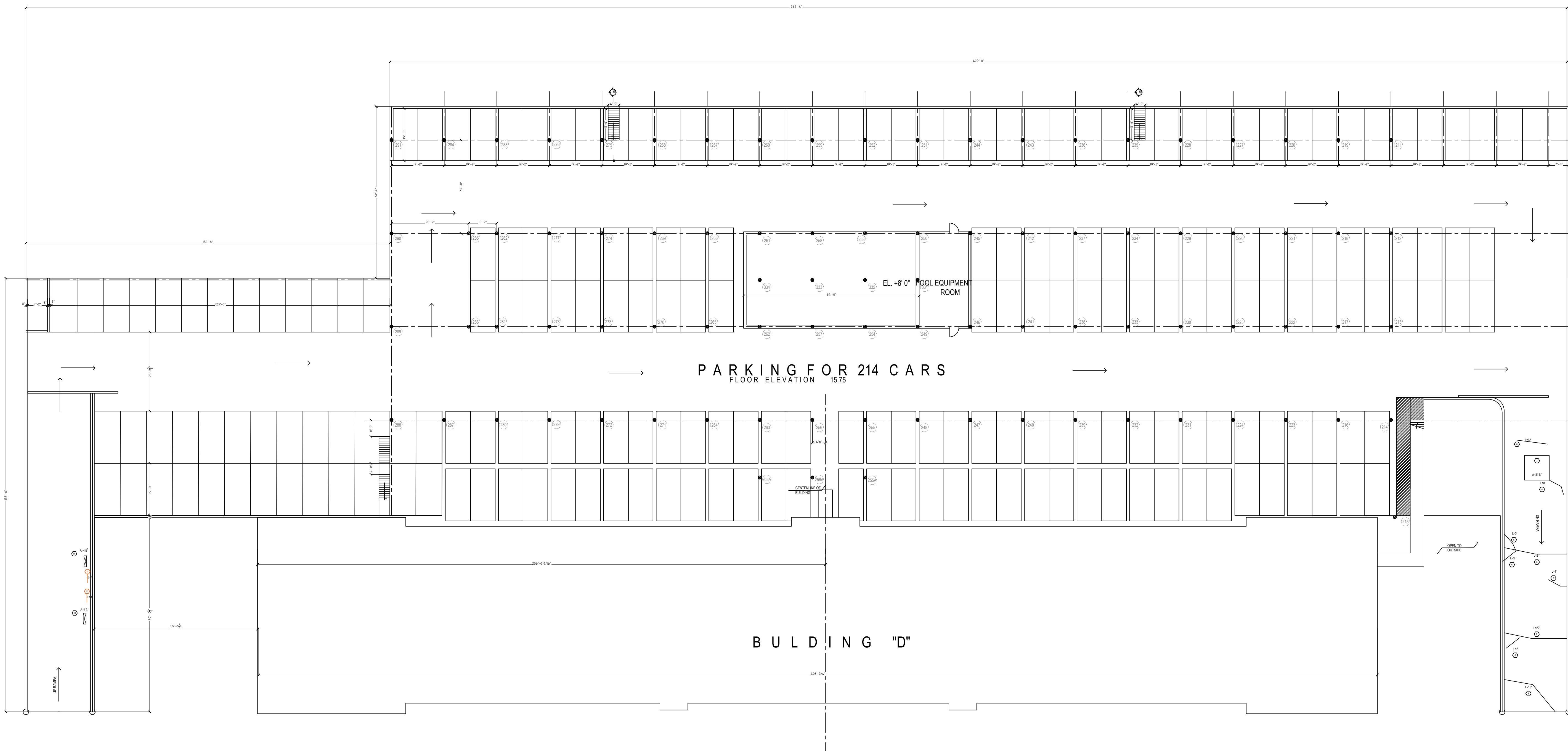

⑤	HAIRLINE CRACK SLAB OVERHEAD PARTIAL DEPTH
⑥	HAIRLINE CRACK SLAB FULL DEPTH
⑦	PARTIAL DEPTH SPALLED CONCRETE OVERHEAD
⑧	FULL DEPTH CONCRETE REPAIR SLAB
⑨	EDGE RAPAIR
⑩	JOIST REPAIR
⑪	BEAM REPAIR
⑫	COLD JOINT
⑬	EXPANSION JOINT
⑭	HAIRLINE CRACK ON SLAB PARTIAL DEPTH
⑮	PARTIAL DEPTH SPALLED CONCRETE

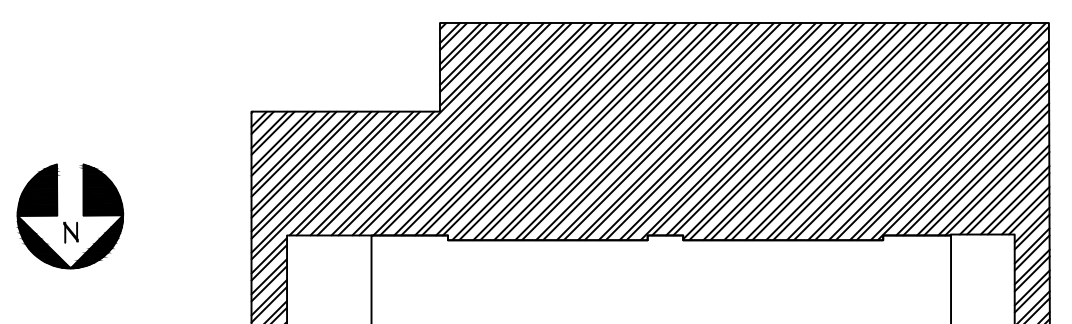

KEY PLAN

**RAMPS PARKING BUILDING
WISTON TOWER 100**

SCALE: 3/32" = 1'-0"

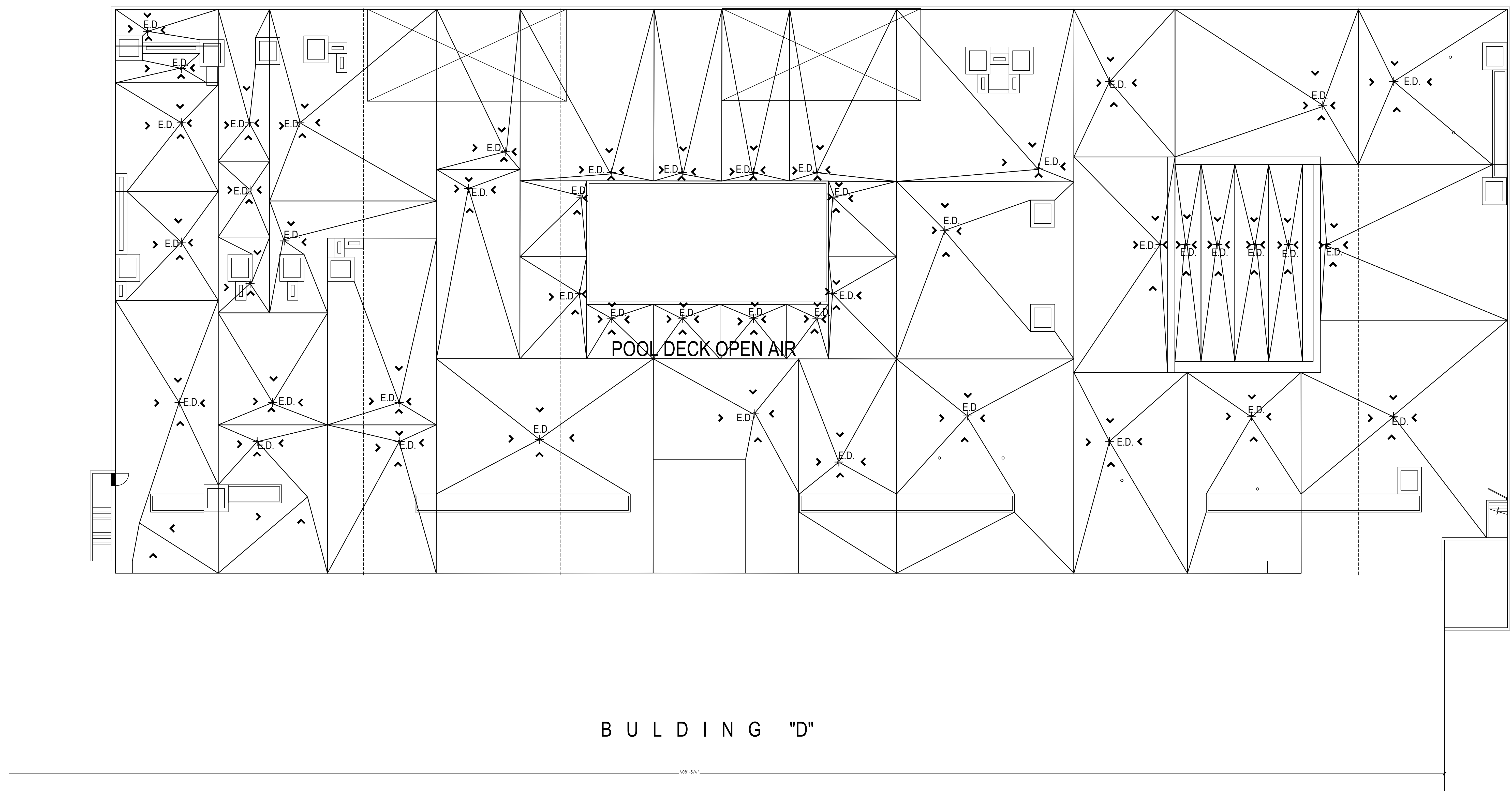
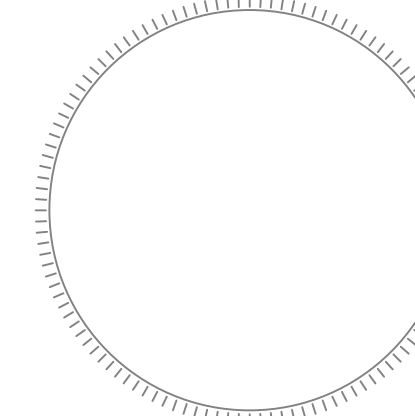
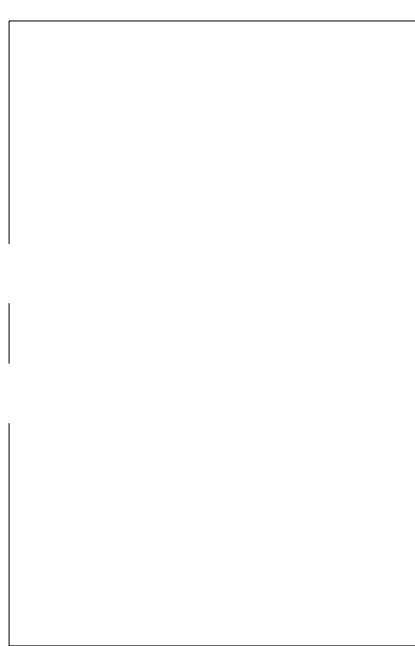

BUILDING "D"

E.D. EXISTING DRAIN TO REMAIN

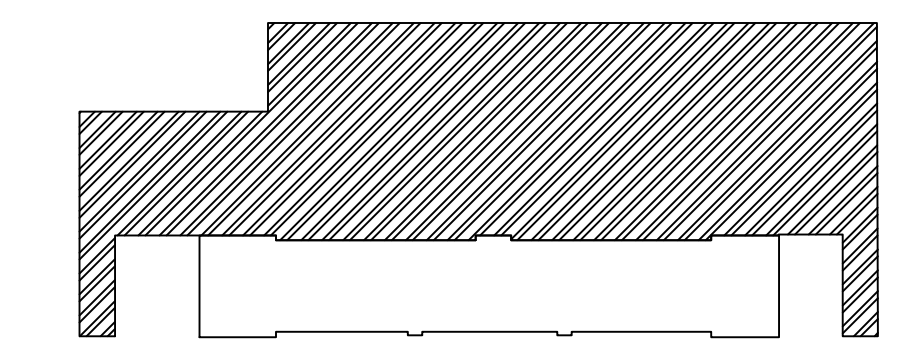

KEY PLAN

**DRAINAGE POOL DECK
PARKING BUILDING
WISTON TOWER 100**

SCALE: 3/32" = 1'-0"

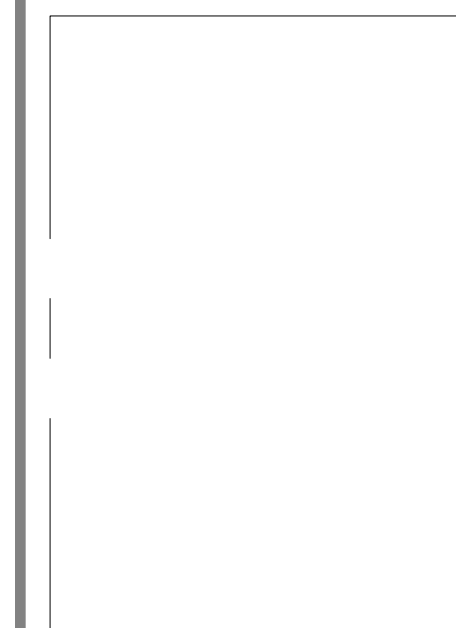

CONSULTING ENGINEER

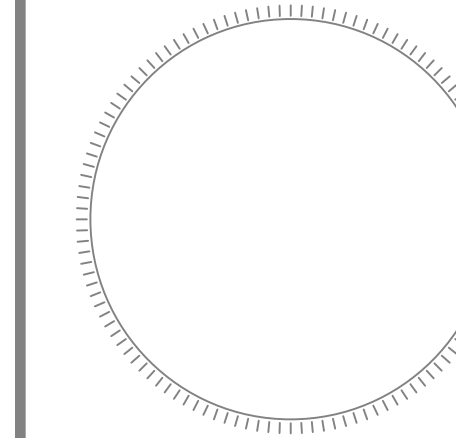

ALIOSKAR GANEM P.E.
FL. LIC. No. 74745

PROJECT NAME:
CONCRETE RESTORATION

PROJECT ADDRESS:
250 174th ST, SUNNY ISLES BEACH
33160 Florida.

REVISIONS DATE

REVISIONS	DATE

Project No:
Scale:
Date: AS NOTED
Drawn: 08-15-2021
Checked: A.G.
CAD File: A.G.

Drawing Title:

S-10

Sheet No: OF

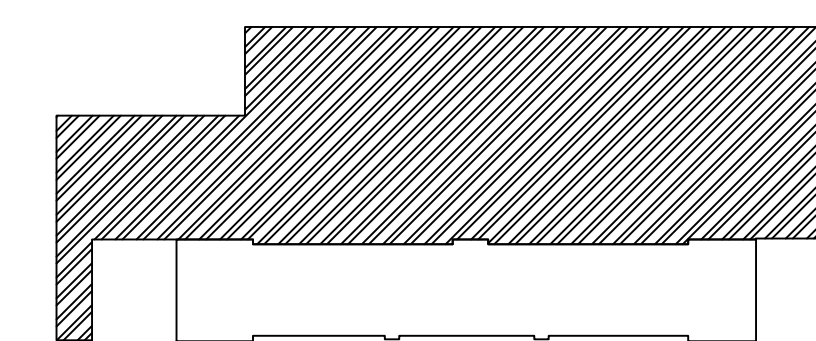
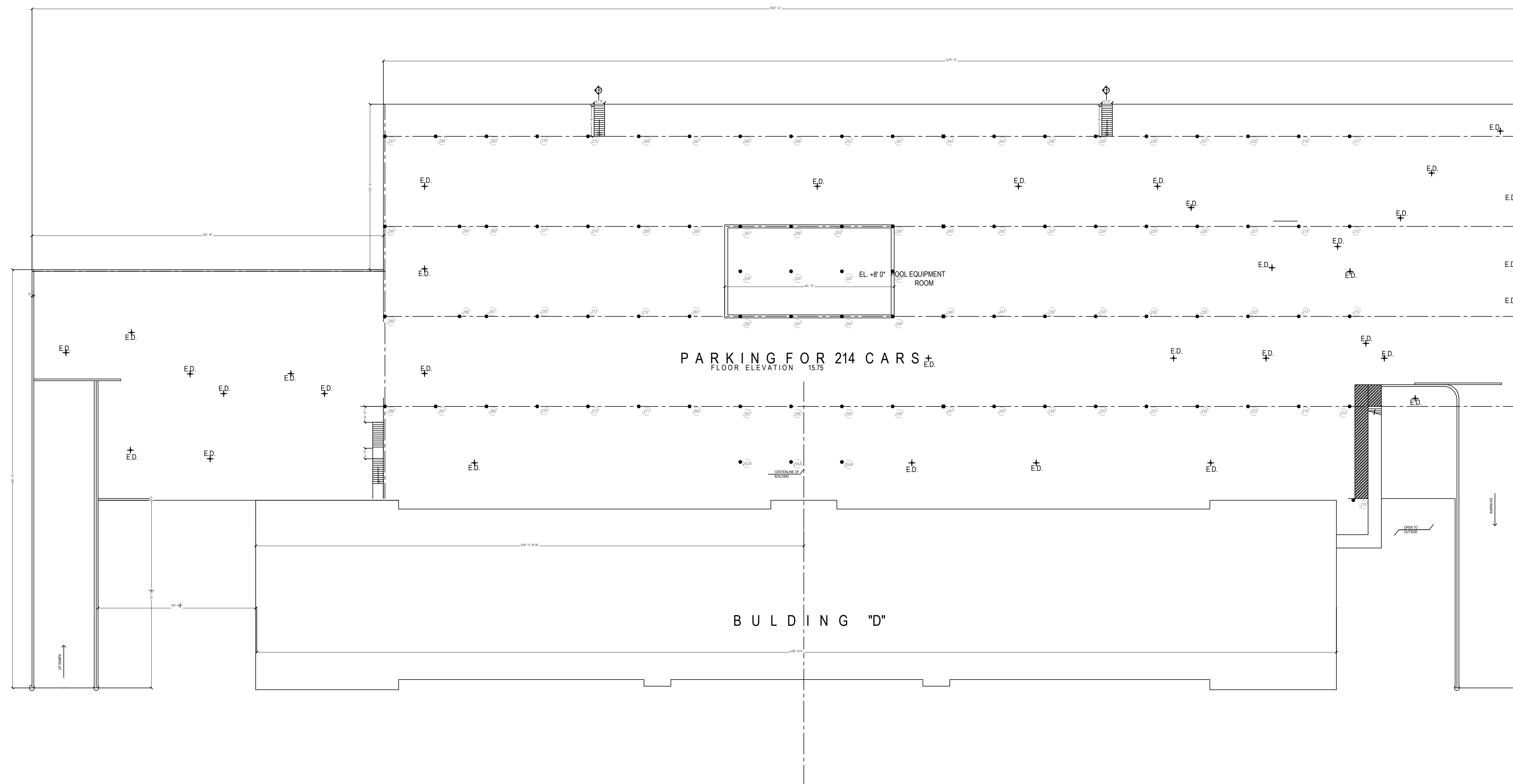

KEY PLAN

**DRAINAGE 2ND FLOOR
(EXISTING DRAINS TO REMAIN)
PARKING BUILDING
WISTON TOWER 100**

SCALE: 3/32" = 1'-0"

PARKING GARAGE_WISTON TOWER_CONCRETE RESTORATION.dwg

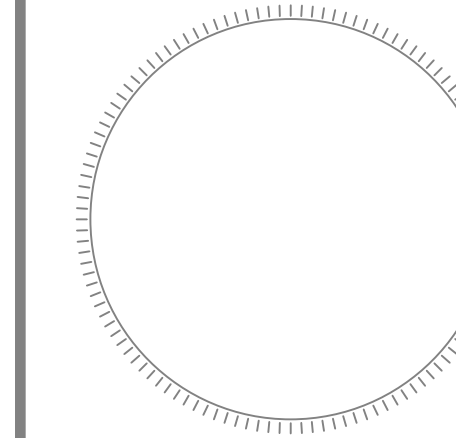
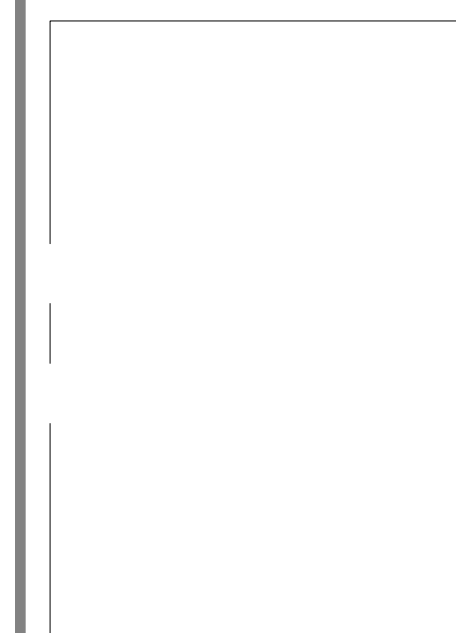

REVISIONS	DATE

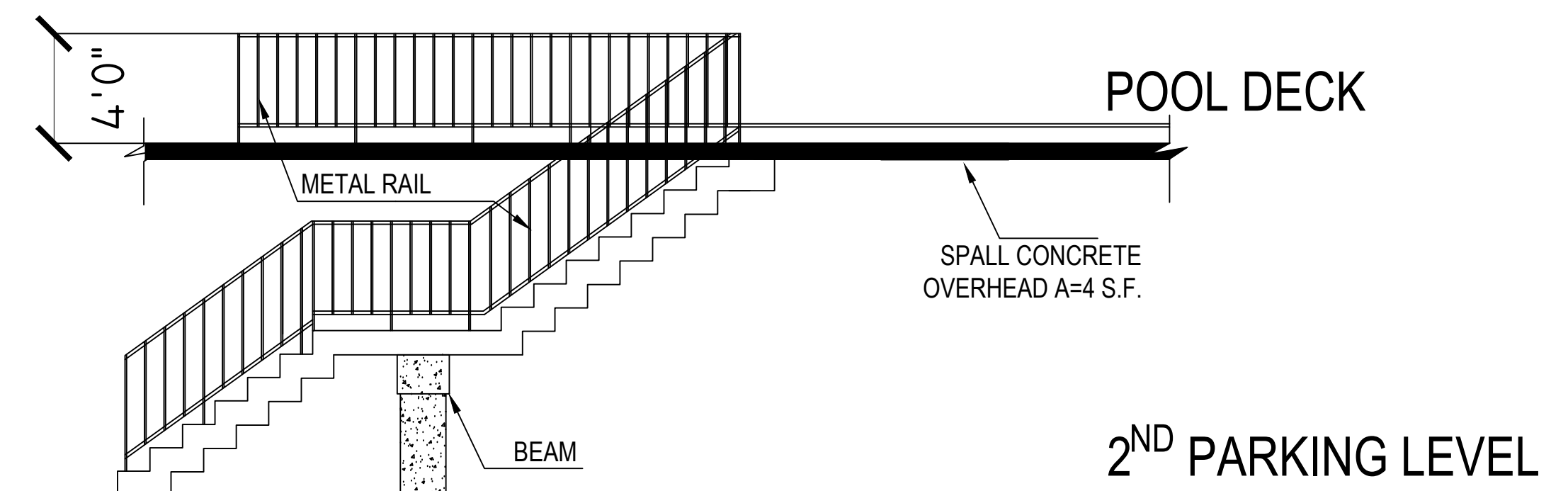
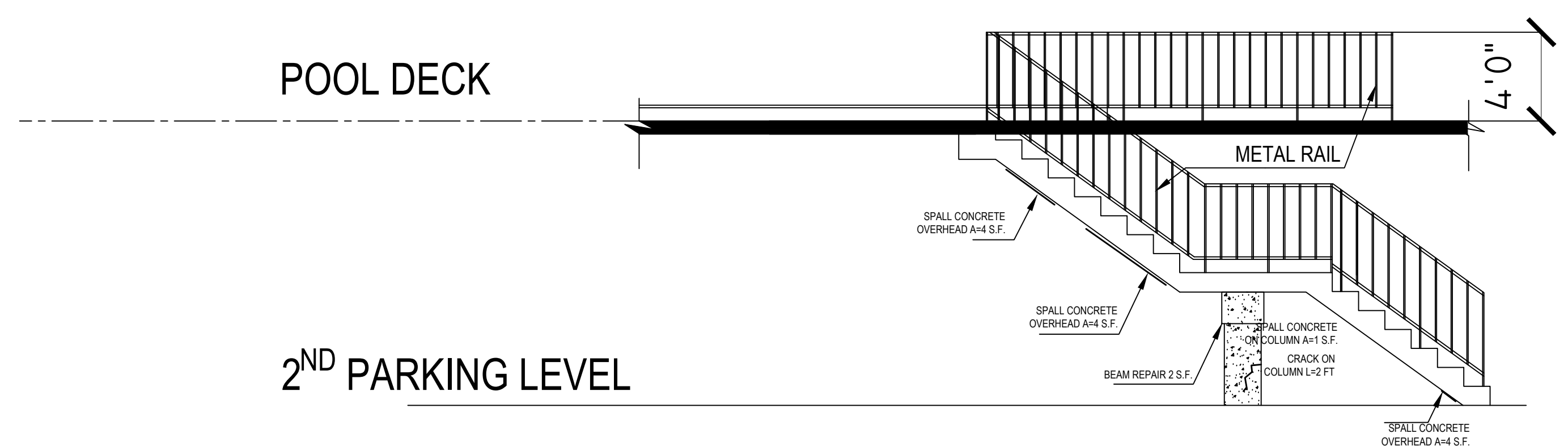

REPARATION LEGEND	
①	HAIRLINE CRACK ON COLUMNS
②	SPALL CONCRETE PARCIAL ON COLUMNS
③	PATCHING TO BE REPAIR ON COLUMNS
④	HONEYCOMB ON COLUMNS

REPARATION LEGEND	
⑤	HAIRLINE CRACK SLAB OVERHEAD PARTIAL DEPTH
⑥	HAIRLINE CRACK SLAB FULL DEPTH
⑦	PARTIAL DEPTH SPALLED CONCRETE OVERHEAD
⑧	FULL DEPTH CONCRETE REPAIR SLAB
⑨	EDGE RAPAIR
⑩	JOIST REPAIR
⑪	BEAM REPAIR
⑫	COLD JOINT
⑬	EXPANSION JOINT
⑭	HAIRLINE CRACK ON SLAB PARTIAL DEPTH
⑮	PARTIAL DEPTH SPALLED CONCRETE

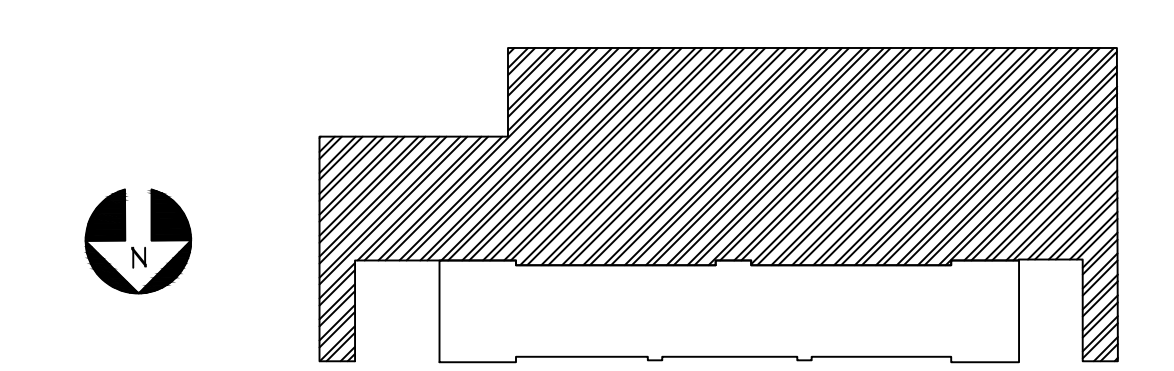

KEY PLAN

**STAIRS PARKING BUILDING
WISTON TOWER 100**
SCALE: 3/32" = 1'-0"

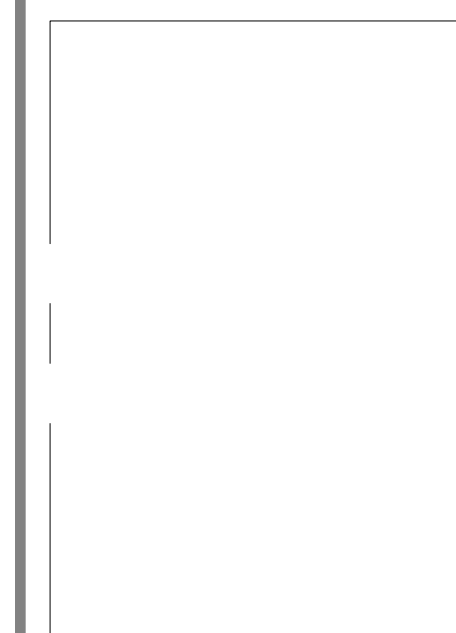

CONSULTING ENGINEER

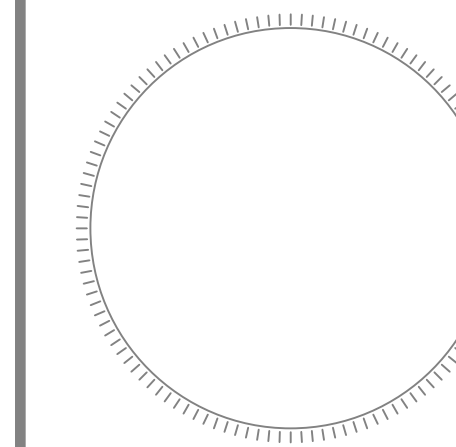

ALIOSKAR GANEM P.E.
FL. LIC. No. 74745

PROJECT NAME:
CONCRETE RESTORATION

PROJECT ADDRESS:
250 174th ST, SUNNY ISLES BEACH
33160 Florida.

REVISIONS DATE

REVISIONS	DATE

Project No:
Scale:
Date: AS NOTED
Drawn: 08-15-2021
Checked: A.G.
CAD File: A.G.

Drawing Title:

S-12

Sheet No: OF

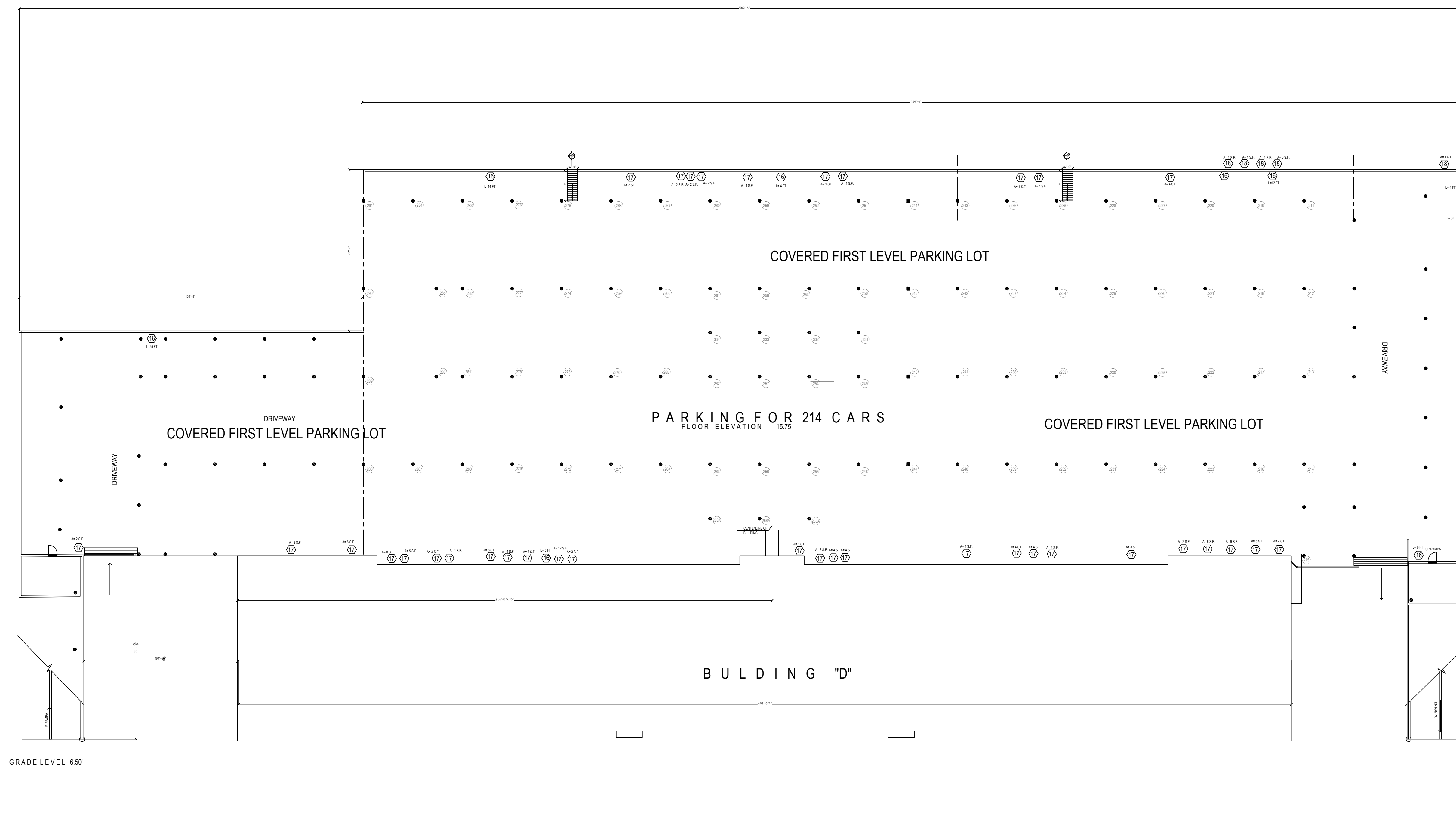

REPARATION LEGEND	
	HAIRLINE CRACK WALLS
	STUCCO
	PARTIAL DEPTH SPALLED CONCRETE WALLS

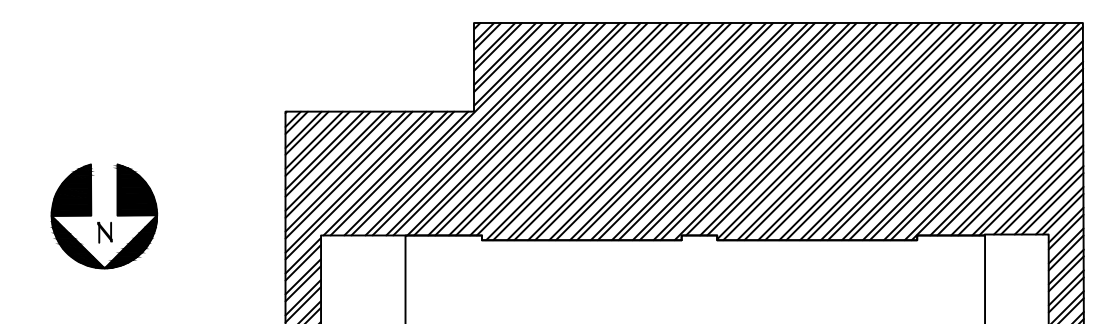

KEY PLAN

**WALL REPAIR GROUND FLOOR
PARKING BUILDING
WISTON TOWER 100**
SCALE: 3/32" = 1'-0"

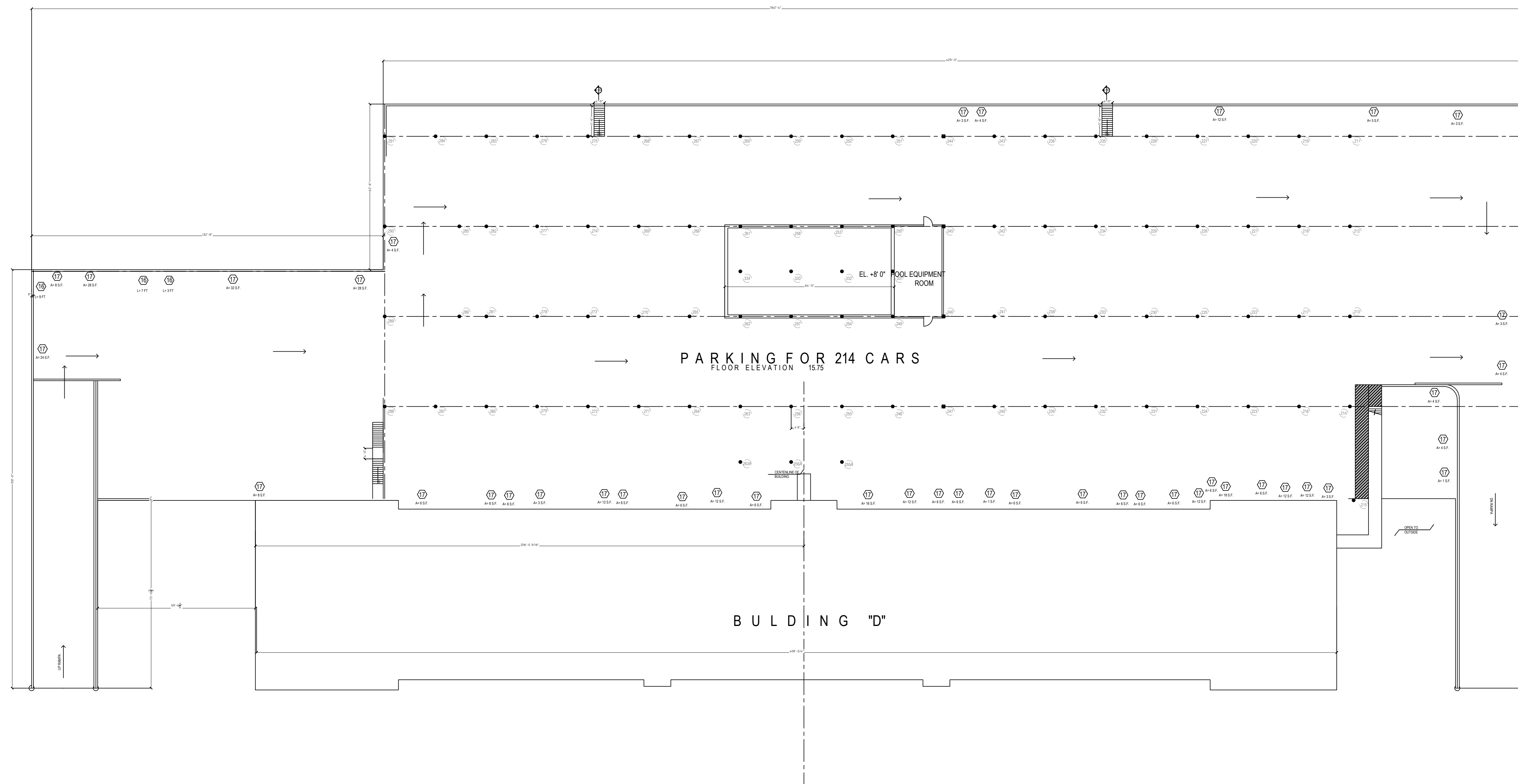

REPARATION LEGEND	
	HAIRLINE CRACK WALLS
	STUCCO
	PARTIAL DEPTH SPALLED CONCRETE WALLS

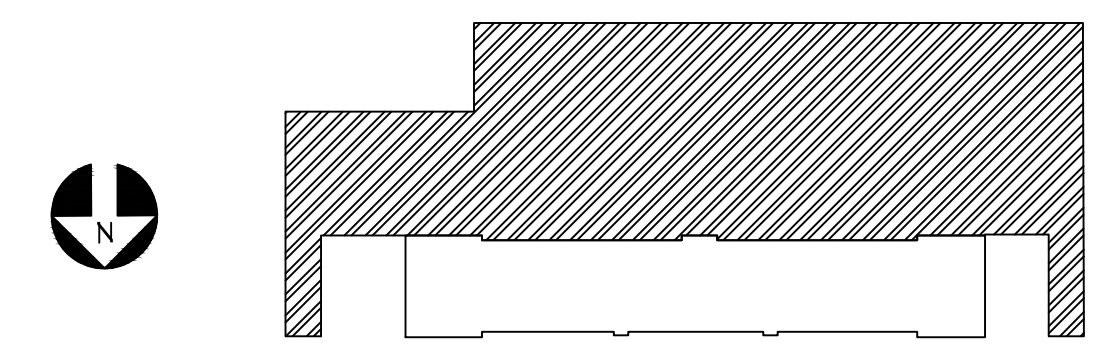

KEY PLAN

**WALL REPAIR 2ND FLOOR
PARKING BUILDING
WISTON TOWER 100**
SCALE: 3/32" = 1'-0"

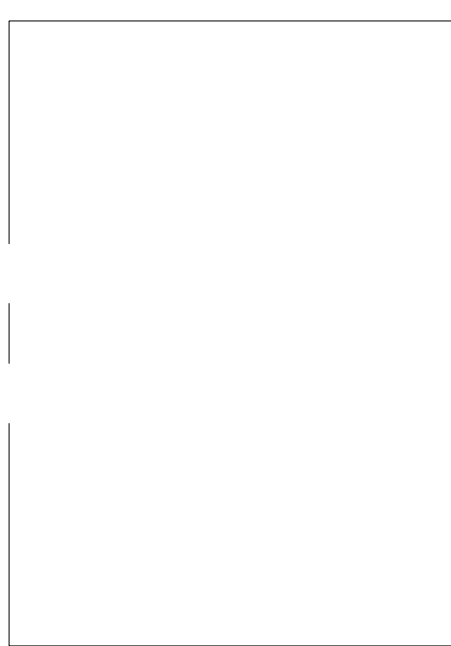

CONSULTING ENGINEER

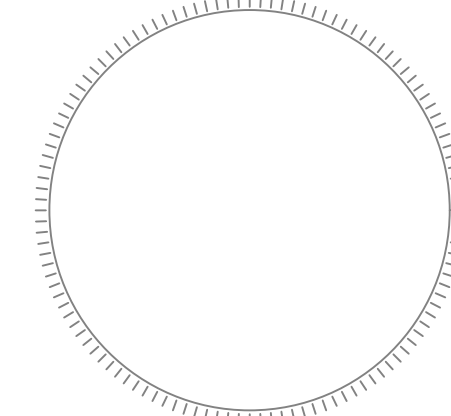

ALIOSKAR GANEM P.E.
FL. LIC. No. 74745

PROJECT NAME:
CONCRETE RESTORATION

PROJECT ADDRESS:
250 174th ST, SUNNY ISLES BEACH
33160 Florida.

REVISIONS	DATE

Project No:
Scale:
Date: AS NOTED
Drawn: 08-15-2021
Checked: A.G.
CAD File: A.G.

Drawing Title:

S-13

Sheet No: OF

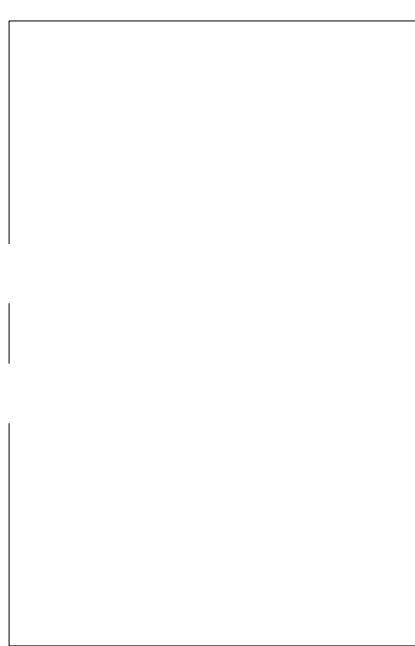

CONSULTING ENGINEER

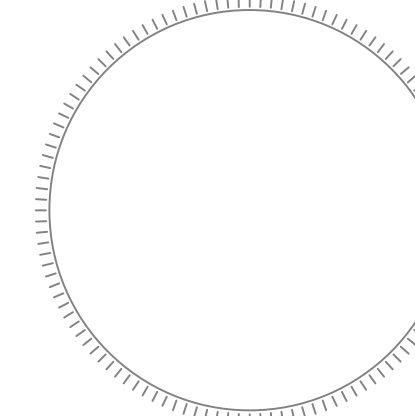

ALIOSKAR GANEM P.E.
FL. LIC. No. 74745

PROJECT NAME:
CONCRETE RESTORATION

PROJECT ADDRESS:
250 174th ST, SUNNY ISLES BEACH
33160 Florida.

REVISIONS DATE

REVISIONS	DATE

Project No:
Scale:
Date: AS NOTED
Drawn: 08-15-2021
Checked: A.G.
CAD File: A.G.

Drawing Title:

S-14

Sheet No: OF

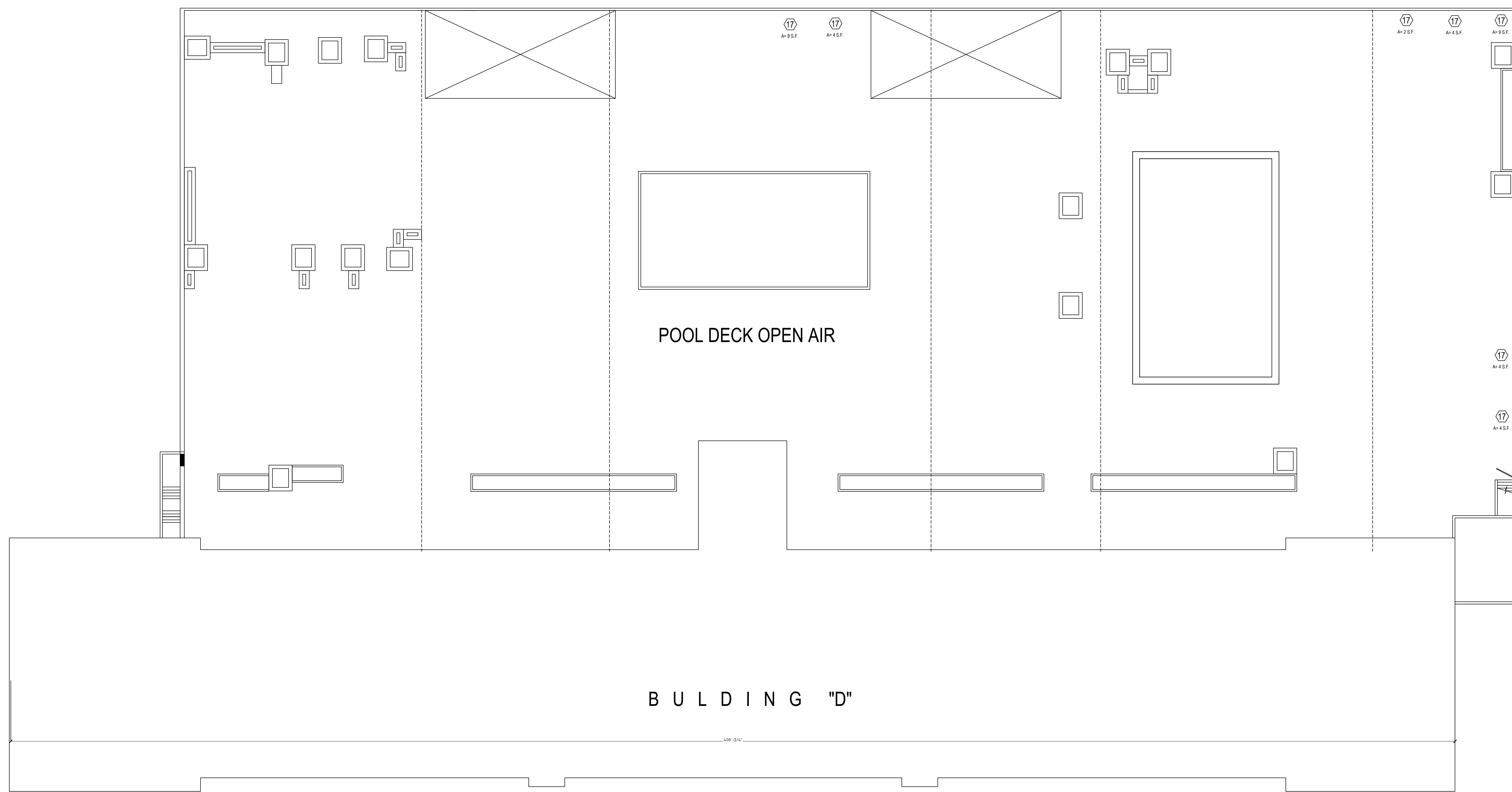

REPARATION LEGEND

16	HAIRLINE CRACK WALLS
17	STUCCO
18	PARTIAL DEPTH SPALLED CONCRETE WALLS

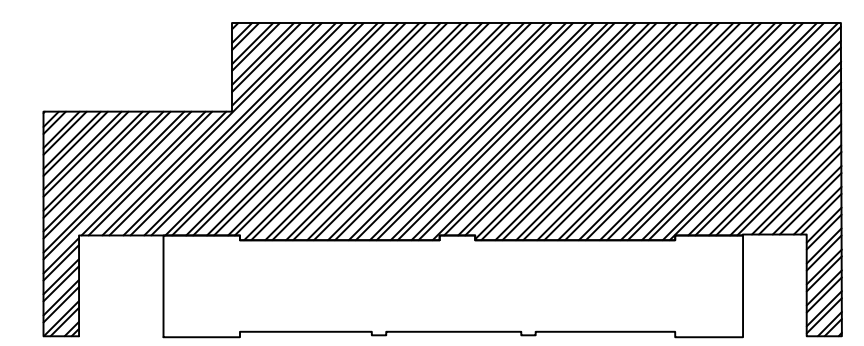
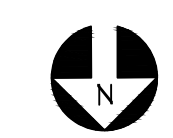

KEY PLAN

**WALL REPAIR POOL DECK
PARKING BUILDING
WISTON TOWER 100**

SCALE: 3/32" = 1'-0"

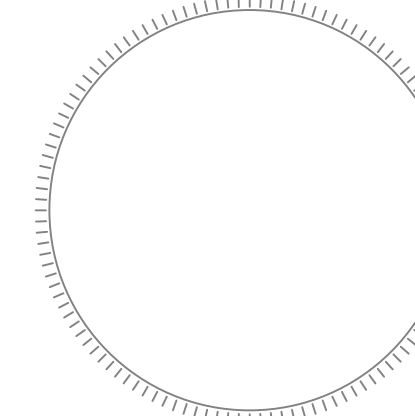
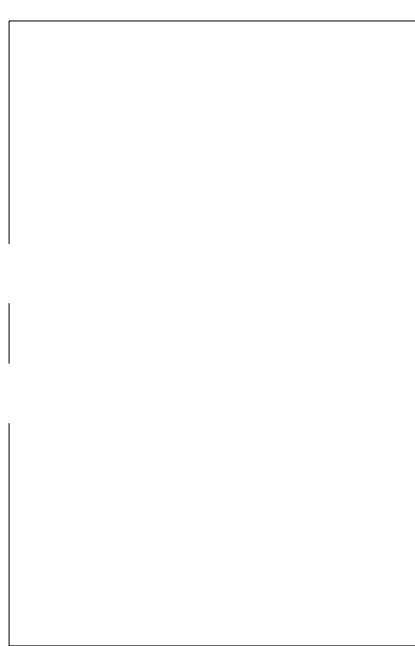

REVISIONS	DATE

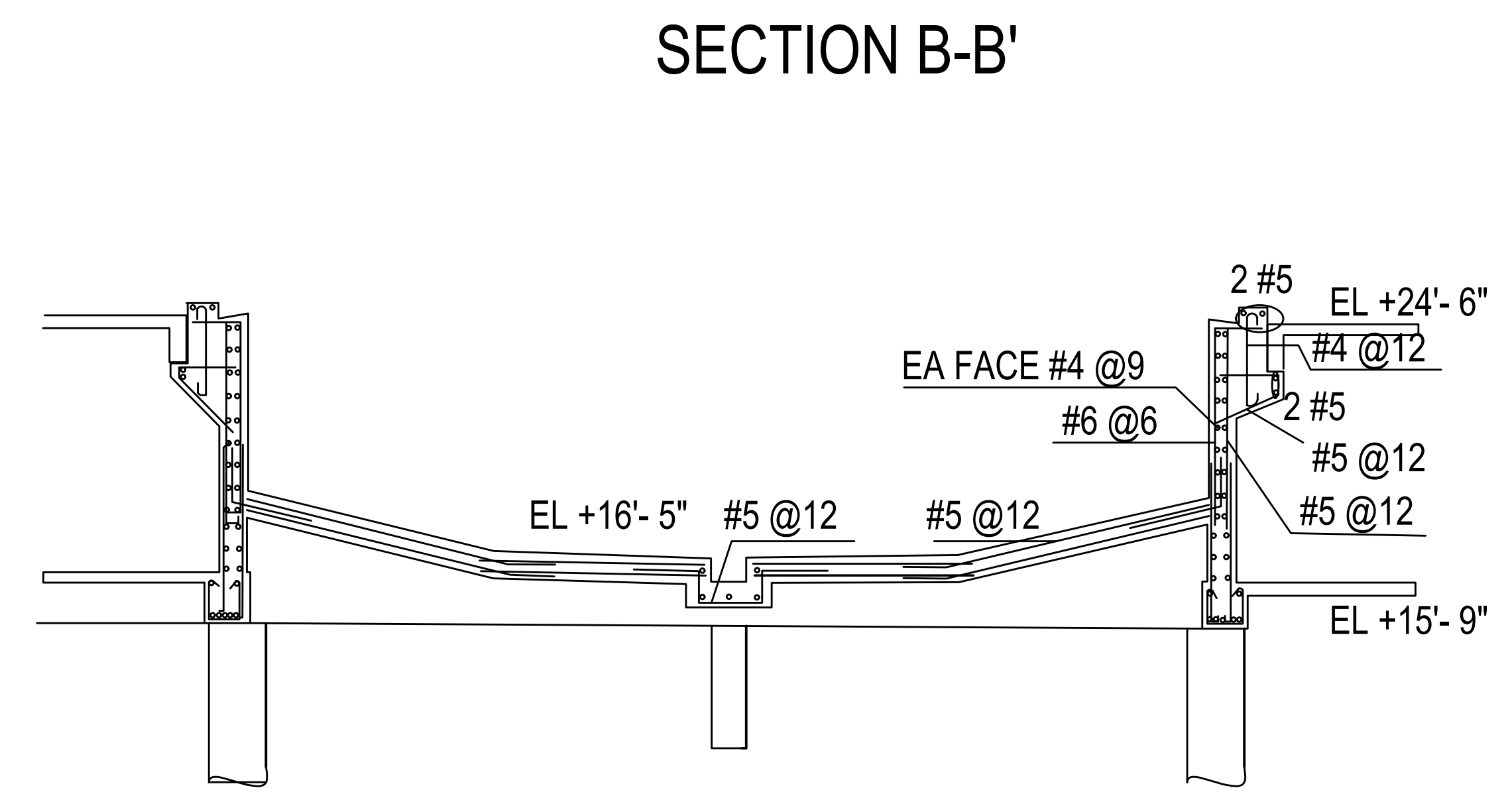
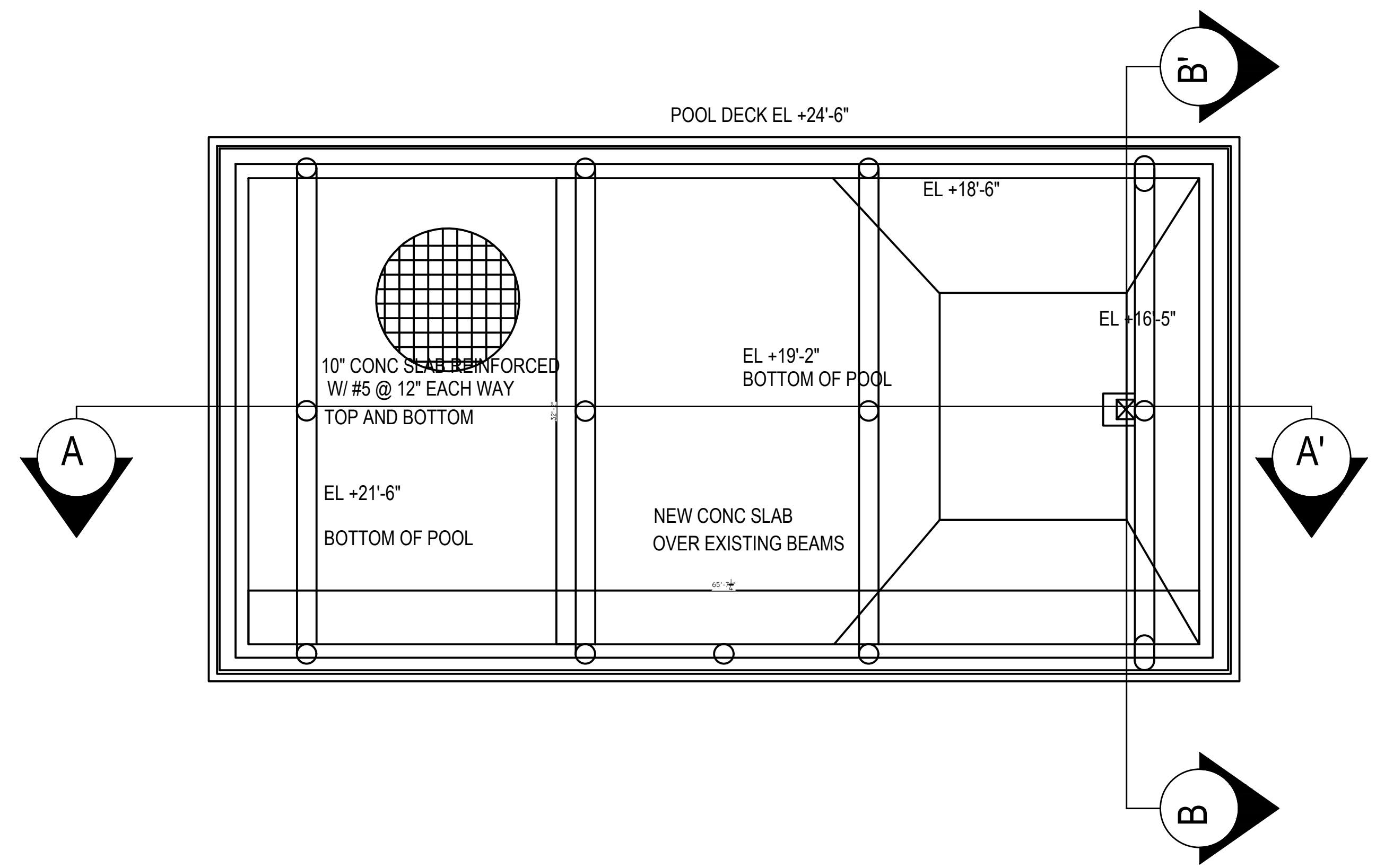

SECTION A-A'

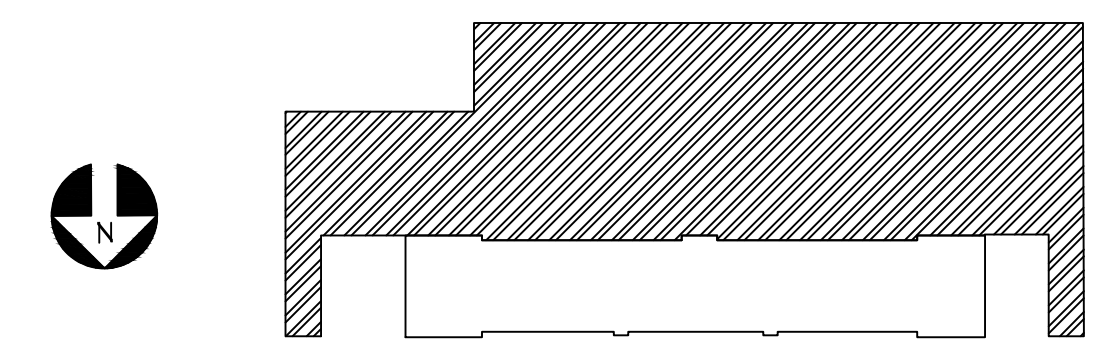
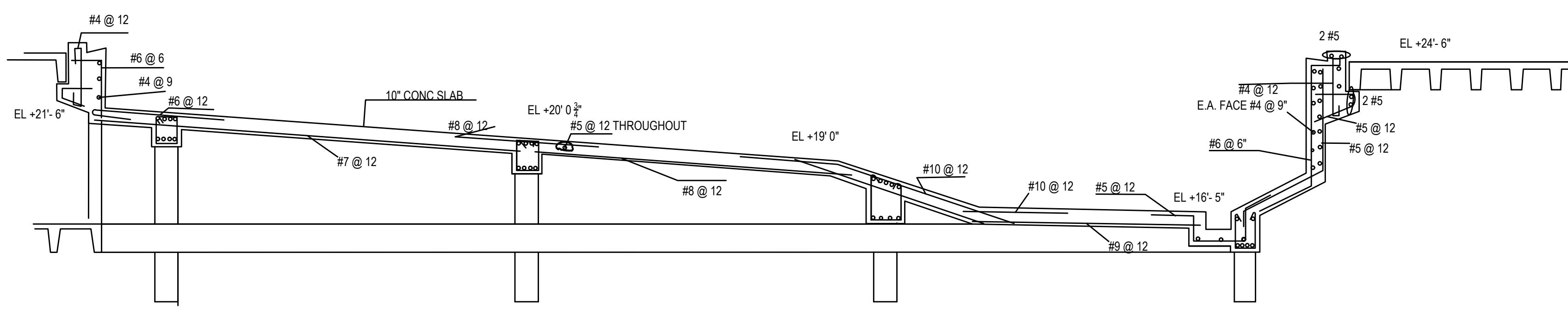

KEY PLAN

**WALL REPAIR POOL DECK
PARKING BUILDING
WISTON TOWER 100**

SCALE: 3/32" = 1'-0"

